

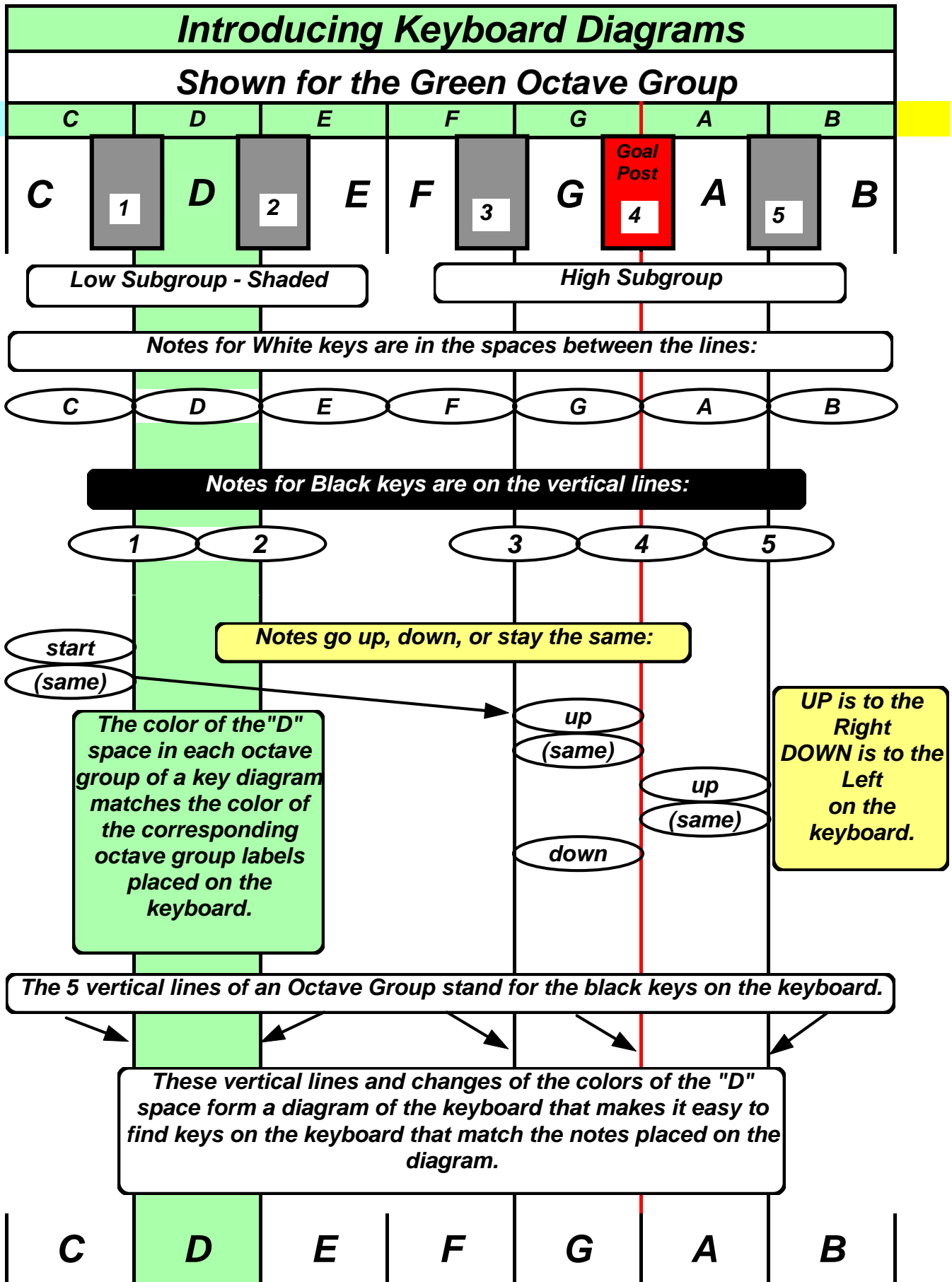

***Page is Blank***

## Contents

<i>About the Keyboard Diagrams</i>	4
<i>Twinkle, Twinkle Little Star</i>	6
<i>Brother John</i>	8
<i>Happy Birthday</i>	10
<i>London Bridge</i>	12
<i>Mary Had a Little Lamb</i>	14
<i>Michael, Row the Boat Ashore</i>	16
<i>Muffin Man</i>	18
<i>Ode to Joy Theme - Beethoven</i>	20



## More About the Diagrams

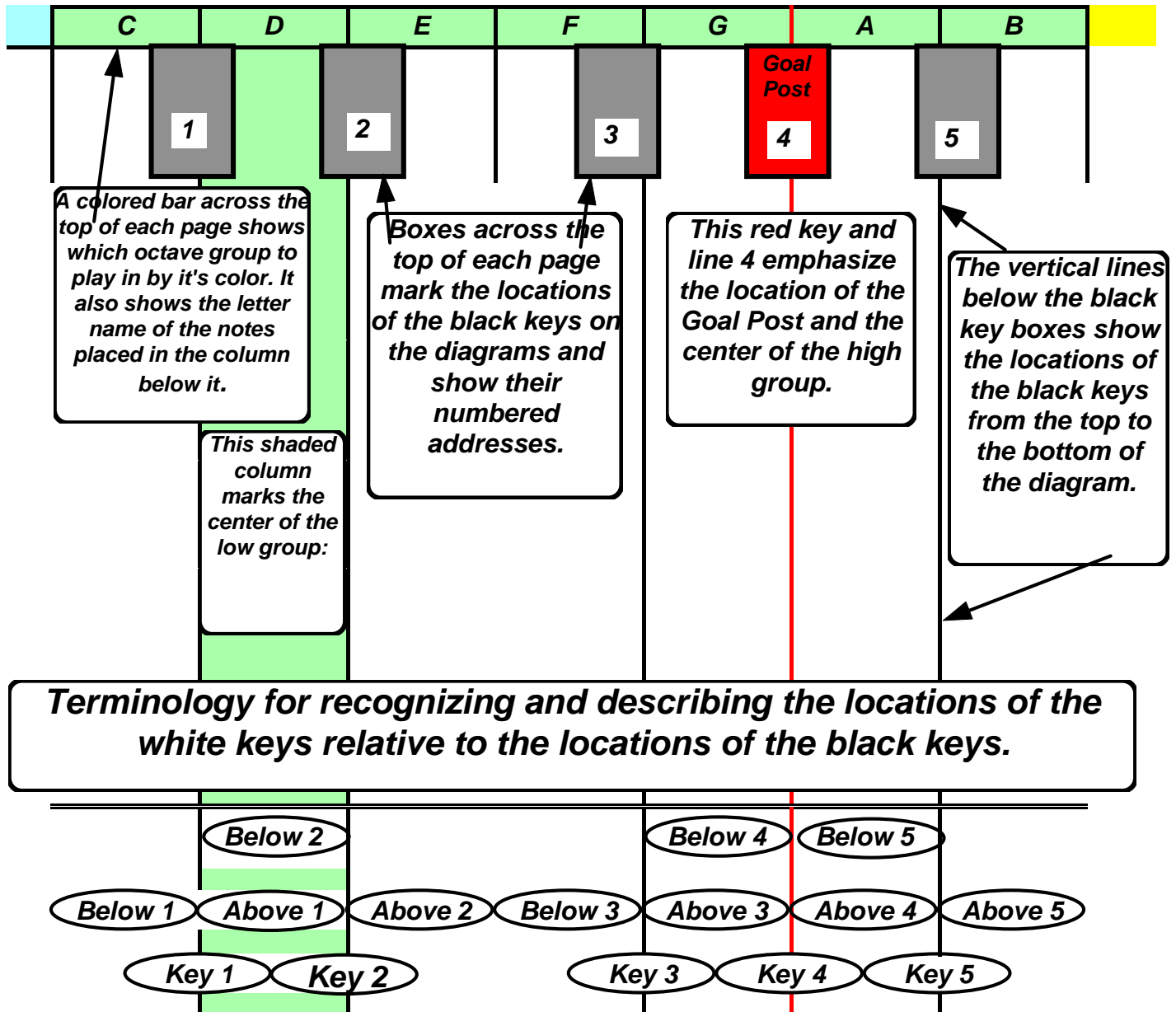

More About the Diagrams

**This Unit shows its songs in two formats. On the pages on the left (like this page) you will find a song on a Key Chart. On the page to its right you will find the same song notated on a Key Diagram. It's intended that this comparison will help you learn to play from the Key Diagram, which is new to you. You will notice that the key diagrams show you which keys to play, but they DON'T show you the rhythm.**

**The Key Diagrams, in turn, are designed to help you (later) to learn to play from the Key Maps, which are also designed to SHOW you which keys to play. In addition, the Key Maps will also SHOW you the RHYTHM of the song and enable you to play multiple notes at the same time.**

**Twinkle, Twinkle, Little Star**

**Focus on Key Names**

*Slowly, with expression    b/#: None    Beats: 4*

L		R			L		R			L		R		
C				Twin-			G	Up			C			Twin-
o				kle,			o	a-			o			kle,
		G		twin-			F	bove			G			twin-
		o		kle,			o	the			o			kle,
			A	lit-		E		world				A		lit-
			o	tle		o		so				o		tle
		G		star.		D		high,			G			star.
			F	How				Like				F		How
		o		I			o	a-			o			I
	E			won-			F	dia-			E			won-
	o			der			o	mond			o			der
D				what		E		in			D			what
o				you		o		the			o			you
C				are,		D		sky.			C			are.

# Twinkle, Twinkle Little Star - Key Finder Diagram

Note that all of the songs on the key diagrams in this unit are identified as the "Key Finder" pages. This songs all are played with the thumbs on E and F in the green octave group - to keep the songs as easy as possible for beginners to play. We call this hand position, The "10 Finger Position" - the 10 fingers all spread out on either side of keys E and F. A finger number is shown next to the first note for each hand.

## Key Finder Pages (Without Rhythm Notation)

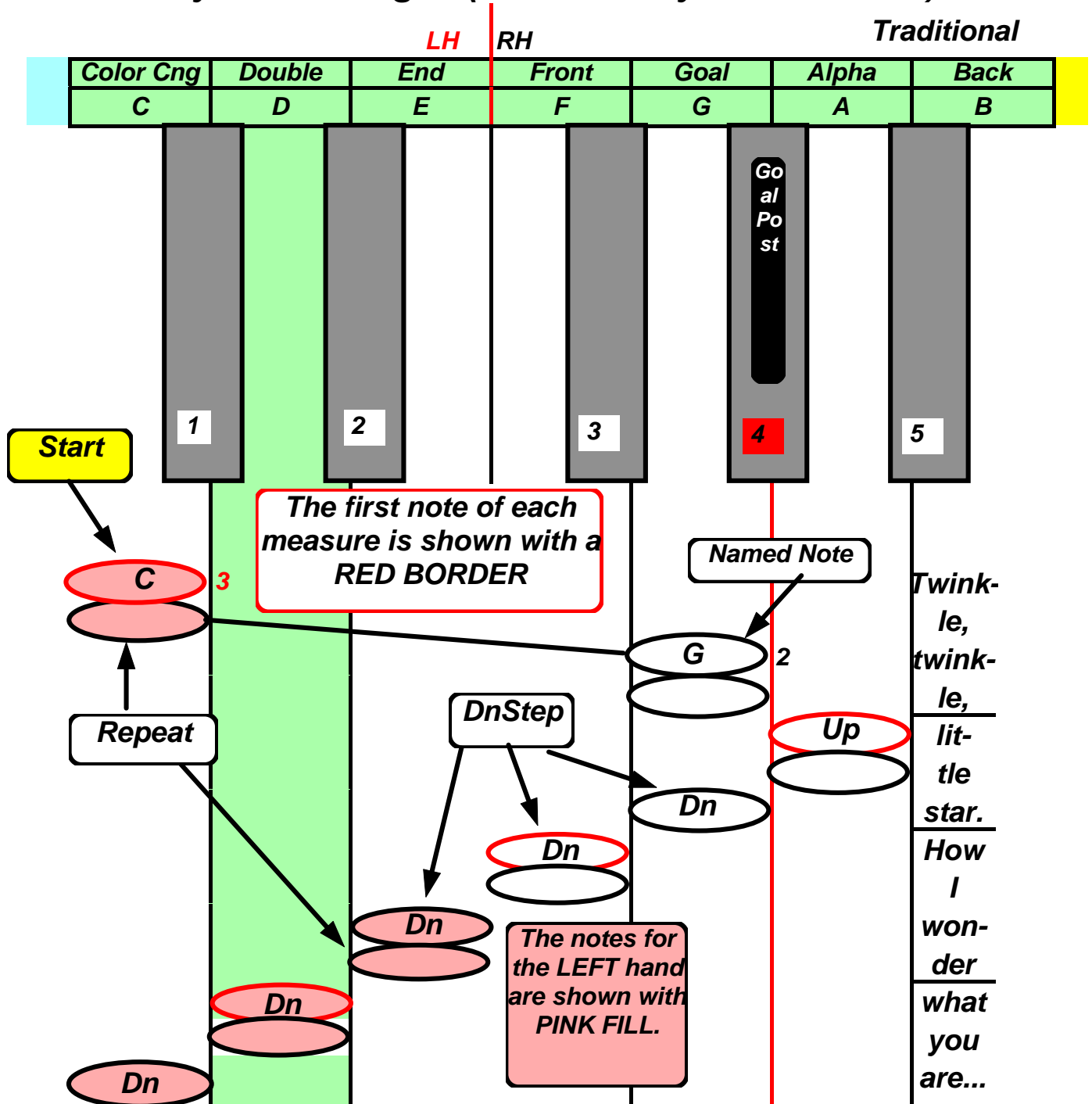

# Brother John

## Focus on Key Names

Moderately    *b*: 5    Beats: 4

L		R				L		R		
C				Are				G	A	Morn-
	D			you				G		ing
	E			sleep-		E		F		bells
C				ing,		C				are
C				Are				G	A	ring-
	D			you				G		ing
	E			sleep-		E		F		bells
C				ing,		C				are
	E			Bro-	1	o				ring-
		F		ther	4	G				ing
			G	John?	1	C				Ding,
	E			Bro-		o				Ding,
		F		ther	4	G				Dong
			G	John?	1	C				Ding,

Play with your thumbs on E and F (10 Finger Position).



# Brother John - Key finder

		LH	RH	Traditional French		
Color Cng	Double	End	Front	Goal	Alpha	Back
C	D	E	F	G	A	B
	1	2	3	4	5	
C	Up	Up		Play with your thumbs on E and F (10 Finger Position).		Are you sleep-
C	Up	Up				ing,
C	Up	Up				Are you sleep-
C	Up	E	Up			ing,
		E	Up	1		Brother
			Up	Up		John,
			Up	Up		Brother
				Up		John,
				Dn	Up	Morn-
		Dn	Dn	Dn		ing,
C				G		bells
				Dn	Up	are
		Dn	Dn			ring-
C				G		ing,
C				Dn		Morn-
C				G		ing,
C				Dn		bells
C				G		are
C				Dn		ring-
C				G		ing,
C				Dn		Ding,
C				G		Dong
C				Dn		Ding.
C				G		Ding,
C				Dn		Dong
C				G		Ding.

"Up" identifies the next WHITE key to the RIGHT.  
 "Dn" (down) identifies the next WHITE key to the LEFT.

# Happy Birthday

## Focus on Key Names

*Happily* b: 1 Beats: 3

The easiest way to play this is with your thumbs on E and F (10 Finger Position).

L		R			L		R		
C				Hap-				C	birth-
o				py					day
	D			birth-			A		day
C				day			F		dear
		F		to		E			(Insert)
	E			you,	D				(Name)
								5	Hap-
C				Hap-			A		py
o				py			F		birth-
	D			birth-					day
C				day				G	to
			G	to			F		you,
		F		you,					
C				Hap-					
o				py					

# Happy Birthday - Key Finder

Sarah Hale		LH	RH	Lowell Mason							
Color Cng	Double	End	Front	Goal	Alpha	Back	Color Cng				
C	D	E	F	G	A	B	C				
1		2		3		4		5		1	
3		1		1		1		1		1	
Up		Dn		Up		Dn		Up		Dn	
Dn		Up		Dn		Up		Dn		Up	
Up		Dn		Up		Dn		Up		Dn	
Dn		Up		Dn		Up		Dn		Up	
Up		Dn		Up		Dn		Up		Dn	
Dn		Up		Dn		Up		Dn		Up	
Up		Dn		Up		Dn		Up		Dn	
Dn		Up		Dn		Up		Dn		Up	
Up		Dn		Up		Dn		Up		Dn	
Dn		Up		Dn		Up		Dn		Up	
Up		Dn		Up		Dn		Up		Dn	
Dn		Up		Dn		Up		Dn		Up	
Up		Dn		Up		Dn		Up		Dn	
Dn		Up		Dn		Up		Dn		Up	
Up		Dn		Up		Dn		Up		Dn	
Dn		Up		Dn		Up		Dn		Up	
Up		Dn		Up		Dn		Up		Dn	
Dn		Up		Dn		Up		Dn		Up	
Up		Dn		Up		Dn		Up		Dn	
Dn		Up		Dn		Up		Dn		Up	
Up		Dn		Up		Dn		Up		Dn	
Dn		Up		Dn		Up		Dn		Up	
Up		Dn		Up		Dn		Up		Dn	
Dn		Up		Dn		Up		Dn		Up	
Up		Dn		Up		Dn		Up		Dn	
Dn		Up		Dn		Up		Dn		Up	
Up		Dn		Up		Dn		Up		Dn	
Dn		Up		Dn		Up		Dn		Up	
Up		Dn		Up		Dn		Up		Dn	
Dn		Up		Dn		Up		Dn		Up	
Up		Dn		Up		Dn		Up		Dn	
Dn		Up		Dn		Up		Dn		Up	
Up		Dn		Up		Dn		Up		Dn	
Dn		Up		Dn		Up		Dn		Up	
Up		Dn		Up		Dn		Up		Dn	
Dn		Up		Dn		Up		Dn		Up	
Up		Dn		Up		Dn		Up		Dn	
Dn		Up		Dn		Up		Dn		Up	
Up		Dn		Up		Dn		Up		Dn	
Dn		Up		Dn		Up		Dn		Up	
Up		Dn		Up		Dn		Up		Dn	
Dn		Up		Dn		Up		Dn		Up	
Up		Dn		Up		Dn		Up		Dn	
Dn		Up		Dn		Up		Dn		Up	
Up		Dn		Up		Dn		Up		Dn	
Dn		Up		Dn		Up		Dn		Up	
Up		Dn		Up		Dn		Up		Dn	
Dn		Up		Dn		Up		Dn		Up	
Up		Dn		Up		Dn		Up		Dn	
Dn		Up		Dn		Up		Dn		Up	
Up		Dn		Up		Dn		Up		Dn	
Dn		Up		Dn		Up		Dn		Up	
Up		Dn		Up		Dn		Up		Dn	
Dn		Up		Dn		Up		Dn		Up	
Up		Dn		Up		Dn		Up		Dn	
Dn		Up		Dn		Up		Dn		Up	
Up		Dn		Up		Dn		Up		Dn	
Dn		Up		Dn		Up		Dn		Up	
Up		Dn		Up		Dn		Up		Dn	
Dn		Up		Dn		Up		Dn		Up	
Up		Dn		Up		Dn		Up		Dn	
Dn		Up		Dn		Up		Dn		Up	
Up		Dn		Up		Dn		Up		Dn	
Dn		Up		Dn		Up		Dn		Up	
Up		Dn		Up		Dn		Up		Dn	
Dn		Up		Dn		Up		Dn		Up	
Up		Dn		Up		Dn		Up		Dn	
Dn		Up		Dn		Up		Dn		Up	
Up		Dn		Up		Dn		Up		Dn	
Dn		Up		Dn		Up		Dn		Up	
Up		Dn		Up		Dn		Up		Dn	
Dn		Up		Dn		Up		Dn		Up	
Up		Dn		Up		Dn		Up		Dn	
Dn		Up		Dn		Up		Dn		Up	
Up		Dn		Up		Dn		Up		Dn	
Dn		Up		Dn		Up		Dn		Up	
Up		Dn		Up		Dn		Up		Dn	
Dn		Up		Dn		Up		Dn		Up	
Up		Dn		Up		Dn		Up		Dn	
Dn		Up		Dn		Up		Dn		Up	
Up		Dn		Up		Dn		Up		Dn	
Dn		Up		Dn		Up		Dn		Up	
Up		Dn		Up		Dn		Up		Dn	
Dn		Up		Dn		Up		Dn		Up	
Up		Dn		Up		Dn		Up		Dn	
Dn		Up		Dn		Up		Dn		Up	
Up		Dn		Up		Dn		Up		Dn	
Dn		Up		Dn		Up		Dn		Up	
Up		Dn		Up		Dn		Up		Dn	
Dn		Up		Dn		Up		Dn		Up	
Up		Dn		Up		Dn		Up		Dn	
Dn		Up		Dn		Up		Dn		Up	
Up		Dn		Up		Dn		Up		Dn	
Dn		Up		Dn		Up		Dn		Up	
Up											

# London Bridge

## Focus on Key Names

*Lively* b/#: None Beats: 4

L		R			L		R		
		G		Lon-			G		Lon-
			A	don				A	don
		G		bridge			G		bridge
		F		is			F		is
	E			fal-		E			fal-
		F		ling			F		ling
			G	down,				G	down,
	D			Fal-		D			My
	E			ling					
		F		down,			G		fair
	E			Fal-		E			La-
		F		ling		C			dy.
			G	down,					

*The easiest way to play this is with your thumbs on E and F (10 Finger Position).*



**Mary Had a Little Lamb**

**Focus on Key Names**

Brightly b/#: None Beats: 4

L		R			L		R		
	E			Ma-		E			Ma-
D				ry	D				ry
C				had	C				had
	D			a		D			a
	E			lit-		E			lit-
	o			tle		o			tle
	o			lamb,		o			lamb,
						o			its
D				lit-	D				fleece
o				tle	o				was
o				lamb,		E			white
					D				as
	E			lit-	C				snow.
		G		tle					
		o		lamb,					

Pitch Notation Only

**Mary Had a Little Lamb - Key Finder**

Sarah Hale

LH RH

Lowell Mason

Color Cng	Double	End	Front	Goal	Alpha	Back
C	D	E	F	G	A	B

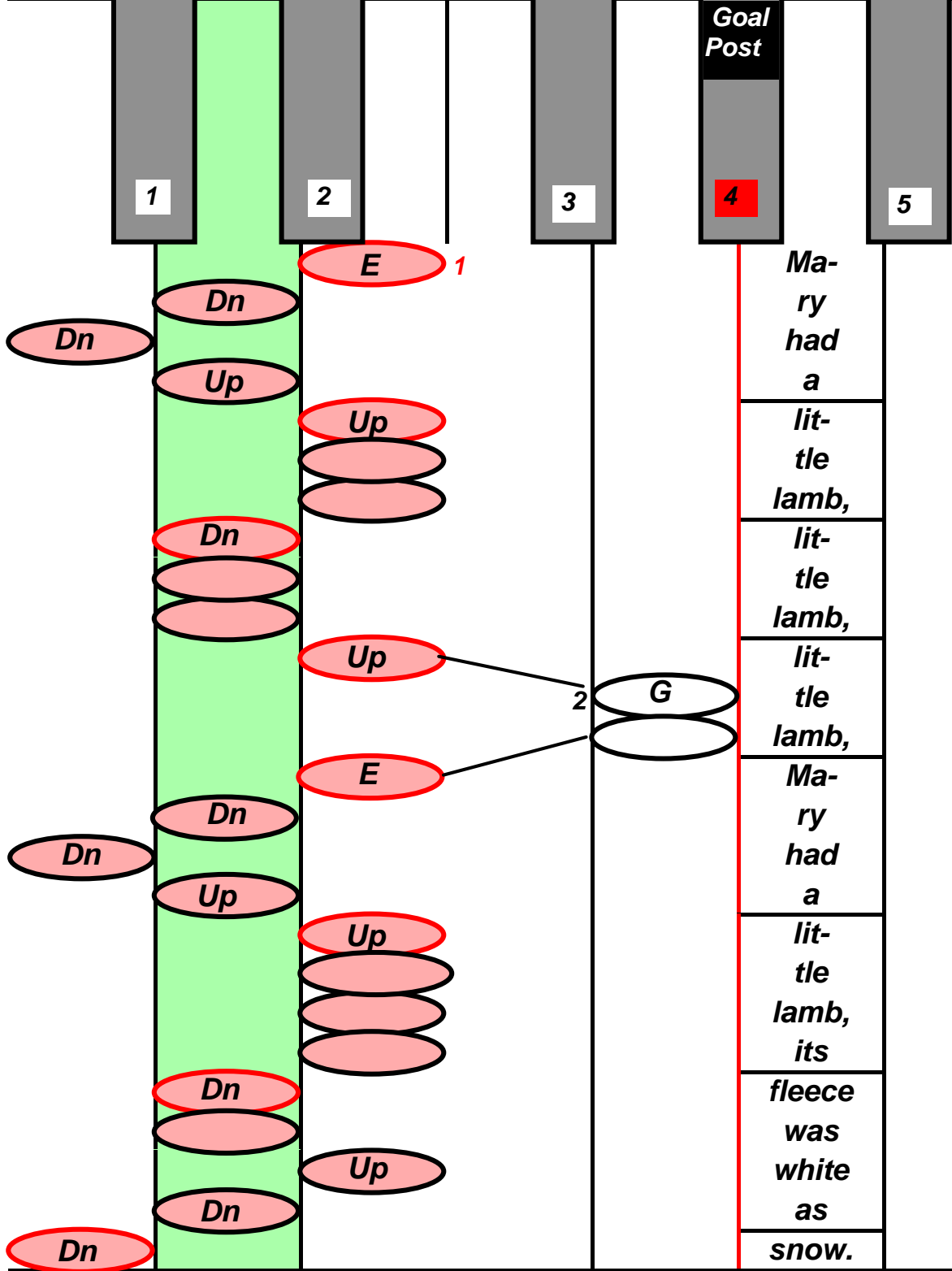

# Michael Row the Boat Ashore

## Focus on Key Names

Quietly *b/#: None Beats: 4*

Play with your thumbs on E and F (10 Finger Position).

L		R			L		R		
C				Mi-			G		Row
	E			chael		E			the
		G		Row			F		boat
	E			the		E			a-
		G		boat	D				shore.
			A	a-					
		G		shore,	C				Ha-
						D			le-
	E			Ha-		E			lu-
		G		le-					
			A	lu-	D				u-
					C				jah!
		G		jah.					
	E			Mi-					
		G		chael					



# Michael, Row the Boat Ashore - Key Finder

		LH		RH		American Folk Song	
Color Cng	Double	End	Front	Goal	Alpha	Back	
C	D	E	F	G	A	B	
1		2		3	4 <small>Goal Post</small>	5	
3		E		G			Mi- chael
		E		G			row the boat a-
		E		Dn	Up		shore, Ha- le-
		E		Dn	Up		lu- jah; Mi- chael
		E		G			row the boat a-
		Dn	Up				shore, Ha- le-
	Dn	Dn					lu- --
Dn	Up						jah!
	Dn						
Dn							

Play with your thumbs on E and F (10 Finger Position).

# Do You Know the Muffin Man?

## Focus on Key Names

Lively *b/#: None Beats: 4*

The easiest way to play this is with your thumbs on E and F (10 Finger Position).

L		R			L		R		
C				Do	C				Do
		F		you			F		you
		o		know			o		know
			G	the				G	the
			A	Muf-				A	Muf-
		F		fin			F		fin
		o		Man,			o		Man,
							o		who
	E			The					
	D			Muf-				G	Lives
		G		fin				o	in
		o		Man,	C				Dru-
		F			o				ry
	E			the			F		Lane?
				Muf-					
	C			fin					
				Man?					
	o								



# Ode to Joy from Beethoven's 9th Symphony

## Focus on Key Names

**Boldly, with expression**

**b/#: None Beats: 4**

**Beethoven**

L		R		L		R		L		R	
	E				E				D		
	o				o				o		
		F			F				E		
			G		G			C			
			G		G			D			
		F			F			E		F	
	E				E			E			
	D				D			C			
	C				C			D			
	o				o			E		F	
	D				D			E			
	E				E			D			
	E				D			C			
	D				C			D			
	o				o			G			

***In addition to playing this famous (5-note) song in the 10-finger position, it can easily be played with the 5 fingers of EITHER hand without changing the hand position while playing (except for the low G near the end of the song). Begin with finger 3 (the middle finger) of either hand.***