

My First Song Collection - Part 3

PC-52

***With Chords for
the Left Hand***

***From the Music
Innovator's Workshop***

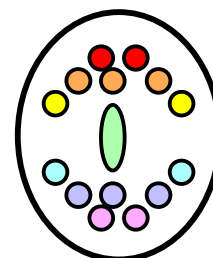

Page is blank.

Contents

	<i>Page</i>
<i>Skip to My Lou</i>	4
<i>Yankee Doodle</i>	6
<i>Polly Wolly Doodle</i>	8
<i>She'll Be Comin' 'Round the Mountain</i>	10
<i>Oh, My Darling Clementine</i>	12
<i>This Old Man</i>	13
<i>Oh, Susanna</i>	14
<i>Down by the Station</i>	16
<i>If You're Happy and You Know It</i>	17
<i>Eensy, Weensy Spider</i>	18
<i>Alphabet Song</i>	19
<i>Home on the Range</i>	20
<i>For He's a Jolly Good Fellow</i>	22
<i>Bingo</i>	23

Skip to my Lou

Traditional American Game Song

Lively #/b: 0 Beats: 2 - starting with the C and G7 chords

The musical notation is presented in two systems, each with two staves. The first system starts with a C chord, followed by a G7 chord, and ends with a C chord. The second system starts with a G7 chord and ends with a G7 chord. Each system is divided into 'Triads' and '4' (quads) sections. Red circles highlight specific notes in the G7 chords: the 1st fret on the 3rd string in the first system, and the 1st and 2nd frets on the 3rd string in the second system.

System 1:

- Staff 1 (C):** Skip, skip, skip, to my Lou, Skip, skip, skip, to my Lou,
- Staff 2 (G7):** Skip, skip, skip, to my Lou, Lou, Skip, Skip, skip, to my Lou,

System 2:

- Staff 1 (G7):** skip, to my Lou, my dar- lin'. Flies in the but-ter-milk, shoo, fly, shoo!
- Staff 2 (G7):** Flies in the but-ter-milk, shoo, fly, shoo!

Skip to my Lou

The diagram shows a guitar fretboard with six strings and five frets. The first three frets are labeled "Triads" and the last two are labeled "4".

- String 6 (top):** C (pink circle) at fret 1. Triads: white circles at frets 1 and 2. Fret 4: orange oval at fret 4. Fret 5: orange oval at fret 5.
- String 5:** Triads: white circles at frets 1 and 2. Fret 4: orange oval at fret 4. Fret 5: orange oval at fret 5.
- String 4:** Triads: white circles at frets 1 and 2. Fret 4: orange oval at fret 4. Fret 5: orange oval at fret 5.
- String 3:** Triads: white circles at frets 1 and 2. Fret 4: orange oval at fret 4. Fret 5: orange oval at fret 5.
- String 2:** Triads: white circles at frets 1 and 2. Fret 4: orange oval at fret 4. Fret 5: orange oval at fret 5.
- String 1 (bottom):** C (pink circle) at fret 1. Triads: white circles at frets 1 and 2. Fret 4: orange oval at fret 4. Fret 5: orange oval at fret 5.

Lyrics to the right of the fretboard:

Flies
in
the
but-
ter-
milk,
shoo,
fly,
shoo!

Skip
to
my
Lou,
my
dar-
lin'.

Yankee Doodle

Early American Folksong

Brightly #: 1 Beats: 2 - adding the G and D7 chords

Chord diagram for the first system of 'Yankee Doodle'. The diagram shows six strings and four frets. A light blue vertical bar covers frets 1 and 2, labeled 'Triads'. A light green vertical bar covers frets 3 and 4, labeled '4'. A yellow vertical bar covers fret 5, labeled '3'. The chords are: G (fret 1), D7 (fret 2), G (fret 3), D7 (fret 4), G (fret 5), and C (fret 5). Fingerings are indicated by numbers 1, 2, 3, and 4. The lyrics are: Father and I went down to camp, A-long with Cap-tain Good-ing And there we saw the men and boys as

Chord diagram for the second system of 'Yankee Doodle'. The diagram shows six strings and four frets. A light blue vertical bar covers frets 1 and 2, labeled 'Triads'. A light green vertical bar covers frets 3 and 4, labeled '4'. The chords are: D7 (fret 1), G (fret 2), C (fret 3), G (fret 4), and C (fret 5). Fingerings are indicated by numbers 1, 2, 3, and 4. The lyrics are: thick as hast-y pud-ding. Yan-kee Doo-dle, keep it up, Yan-kee Doo-dle, dan-dy,

Yankee Doodle

	Triads				4				
C	●	○	○	○	2	○	○	○	○
					2	○	○	○	○
					2	○	○	○	○
					2	○	○	○	○
					2	○	○	○	○
G	○	●	○	○	4	○	○	○	○
					4	○	○	○	○
D7	●	○	○	○	4	○	○	○	○
					4	○	○	○	○
G	○	●	○	○	4	○	○	○	○
					4	○	○	○	○

Mind

the

mus-

ic

and

the

step,

and

with

the

girls

be

hand-

y.

Polly Wolly Doodle

Traditional American Minstrel Song

Adding the F and C7 Chords

Brightly b: 1 Beats: 2

Oh,
I
went
down
South
for
to
see
my
Sal,
sing
ing
pol-
ly-
wol-
ly-
doo-
dle-
all
the
day.

My--
--
Sal
she
is
a

spunk-
y
gal
sing-
ing
pol-
ly-
wol-
ly-
doo-
dle
all
the
day.

Fare
thee
well,

Fare
thee
Well

Fare
thee
well,
my
fair-
y

Polly Wolly Doodle

The image displays a guitar chord chart for the song "Polly Wolly Doodle". It features a six-string guitar fretboard with the following elements:

- Chords:** C7 (top left), F (bottom left), and a 4-finger barre (top right).
- Triads:** A section labeled "Triads" is highlighted in light blue, covering the first three frets.
- Lyrics:** "fay," "For I'm goin'- to Lou'-si-an-a, for to see my Su-zi-an-na, Sing-ing pol-ly-wol-ly-doo-dle all the day."
- Visuals:** Colored circles (red, white, green, pink) and ovals indicate fingerings and chord shapes. A yellow vertical bar is on the right side of the fretboard.

She'll Be Comin' 'Round the Mountain

Western American Folksong

○ Moderately #: 1 Beats: 4 - adding the A7 chord

Triads | 4

G

2

5

1

2

5

1

5

She'll
be
com-
in'
round
the
moun-
tain
when
she
comes,

Triads | 4

D7

G

C7

2

5

4

5

comes.
She'll
be
com-
in'
round
the
moun-
tain,
She'll
be
com-
in'
round
the
moun-
tain,
She'll
be

She'll Be Comin' 'Round the Mountain

The diagram illustrates a guitar chord progression for the song "She'll Be Comin' 'Round the Mountain". It features four strings: G (top), A7, D7, and G (bottom). The fretboard is divided into two sections: "Triads" (frets 1-3) and "4" (fret 4). Fingerings are indicated by numbers 1, 2, 3, and 4. The lyrics are: "com-in", "round", "the moun-tain", "when she comes."

String	Fret 1	Fret 2	Fret 3	Fret 4
G	0	2	0	1
A7	0	2	2	3
D7	2	0	0	1
G	0	2	0	1

Oh, My Darling Clementine

Lively b: 1 Beats: 3

American Mining Song
Montrose

NC
F
C7
F
C7
F

Triads 4

1 3 4

In a cavern, in a canyon, excavating for a mine, Dwelt a miner, forty-niner, and his daughter, Clementine. Oh, my

Detailed description: This diagram shows the first system of guitar chords for the song. It consists of six staves. The first staff is labeled 'NC' and has a pink circle on the 1st fret of the 1st string. The second staff is labeled 'F' and has pink circles on the 1st fret of the 1st, 2nd, and 3rd strings. The third staff is labeled 'C7' and has a pink circle on the 1st fret of the 5th string. The fourth staff is labeled 'F' and has pink circles on the 1st fret of the 1st, 2nd, and 3rd strings. The fifth staff is labeled 'C7' and has a pink circle on the 1st fret of the 5th string. The sixth staff is labeled 'F' and has pink circles on the 1st fret of the 1st, 2nd, and 3rd strings. A green vertical bar highlights the 4th and 5th frets, labeled 'Triads' and '4'. A yellow vertical bar highlights the 3rd fret, labeled '1'. Orange circles represent chords: a pink circle on the 1st fret of the 1st string (NC), a pink circle on the 1st fret of the 1st, 2nd, and 3rd strings (F), a pink circle on the 1st fret of the 5th string (C7), a pink circle on the 1st fret of the 1st, 2nd, and 3rd strings (F), a pink circle on the 1st fret of the 5th string (C7), and a pink circle on the 1st fret of the 1st, 2nd, and 3rd strings (F). Orange circles on the 3rd fret represent the first triad (1), and orange circles on the 4th fret represent the second triad (3) and the fourth triad (4).

(F)
C7
F
C7
F

Triads 4

3 4 # 1

darling Oh, my darling Oh, my darling Clem-entine. You are lost and gone forever, Dreadful sorry, Clem-entine.

Detailed description: This diagram shows the second system of guitar chords. It consists of six staves. The first staff is labeled '(F)' and has pink circles on the 1st fret of the 1st, 2nd, and 3rd strings. The second staff is labeled 'C7' and has a pink circle on the 1st fret of the 5th string. The third staff is labeled 'F' and has pink circles on the 1st fret of the 1st, 2nd, and 3rd strings. The fourth staff is labeled 'C7' and has a pink circle on the 1st fret of the 5th string. The fifth staff is labeled 'F' and has pink circles on the 1st fret of the 1st, 2nd, and 3rd strings. A green vertical bar highlights the 4th and 5th frets, labeled 'Triads' and '4'. A yellow vertical bar highlights the 3rd fret, labeled '3'. A yellow vertical bar highlights the 4th fret, labeled '4'. A yellow vertical bar highlights the 5th fret, labeled '#'. A yellow vertical bar highlights the 1st fret, labeled '1'. Yellow circles represent chords: a pink circle on the 1st fret of the 1st, 2nd, and 3rd strings ((F)), a pink circle on the 1st fret of the 5th string (C7), a pink circle on the 1st fret of the 1st, 2nd, and 3rd strings (F), a pink circle on the 1st fret of the 5th string (C7), a pink circle on the 1st fret of the 1st, 2nd, and 3rd strings (F), and a pink circle on the 1st fret of the 1st, 2nd, and 3rd strings (F). Yellow circles on the 3rd fret represent the third triad (3), and yellow circles on the 4th fret represent the fourth triad (4). Yellow circles on the 5th fret represent the sharp triad (#), and yellow circles on the 1st fret represent the first triad (1).

This Old Man

English Children's Game

Lively #: 2 Beats: 2 - adding the D chord

	Triads		4		
D	● ○ ○		4	○	<i>This old man,</i>
			4	○	<i>he played one,</i>
G	○ ● ○		4	○	<i>He played knick- knack</i>
A7	○ ○ ●		4	○	<i>on my drum. With a</i>

	Triads		4		
D	● ○ ○		1	○	<i>knick- knack pad- dy- whack,</i>
			2	○	<i>give the dog a bone,</i>
A7	○ ○ ●		4	○	<i>this old man came</i>
D	● ○ ○		4	○	<i>roll- ing home.</i>

Oh, Susanna

Stephen C. Foster

Lively #/b: 0 Beats: 2

Triads		4	
C	C	C	C
D	D	D	D
G	G	G	G
C	C	C	C

I

come
from
Al-
a-
bam-
a-
with
a
ban-
jo
on
my
knee.

I'm

goin'
to
Lou'-
si-

Triads		4	
G7	G7	G7	G7
C	C	C	C
F	F	F	F
C	C	C	C
D7	D7	D7	D7

an-
a
my
Su-
san-
na
for
to
see.

Oh!
Su-
san-
na,
oh
don't
you
cry
for

Oh, Susanna

Triads | **4**

G me,
C for
C I
C come
C from
C Al-
C a-
C bam-
C a-
C with
G7 a-
G7 ban-
G7 jo
G7 on
G7 my
C knee.

Down by the Station

Traditional Round

Lively *b: 1* **Beats: 4**

The first part of the musical notation is for the first part of the song. It consists of four staves for the guitar, labeled F, C7, F, C7, F from top to bottom. The first two staves (F and C7) are grouped under a 'Triads' section, and the last two (F and C7) are grouped under a '4' section. The first two staves have a light blue background, and the last two have a light green background. The notes are represented by colored circles: red for F, white for C, and blue for G. The first two staves have notes on the 1st, 2nd, and 3rd strings. The last two staves have notes on the 4th, 5th, and 6th strings. The first two staves have notes on the 1st, 2nd, and 3rd strings. The last two staves have notes on the 4th, 5th, and 6th strings. The first two staves have notes on the 1st, 2nd, and 3rd strings. The last two staves have notes on the 4th, 5th, and 6th strings. The first two staves have notes on the 1st, 2nd, and 3rd strings. The last two staves have notes on the 4th, 5th, and 6th strings.

Down by the station early in the morning, See the little puff-billies all in all row.

The second part of the musical notation is for the second part of the song. It consists of four staves for the guitar, labeled (F), C7, F, C7, F from top to bottom. The first two staves ((F) and C7) are grouped under a 'Triads' section, and the last two (F and C7) are grouped under a '4' section. The first two staves have a light blue background, and the last two have a light green background. The notes are represented by colored circles: red for F, white for C, and blue for G. The first two staves have notes on the 1st, 2nd, and 3rd strings. The last two staves have notes on the 4th, 5th, and 6th strings. The first two staves have notes on the 1st, 2nd, and 3rd strings. The last two staves have notes on the 4th, 5th, and 6th strings. The first two staves have notes on the 1st, 2nd, and 3rd strings. The last two staves have notes on the 4th, 5th, and 6th strings.

See the engine driver pull the little handle. Choo! Choo! Toot! Toot! Off they go!

If You're Happy and You Know It

Traditional American Game Song

Lively b: 1 Beats: 4 - adding the Bb chord

The image displays three systems of musical notation for guitar, each consisting of a treble clef staff with six lines. The notation includes chord diagrams and fingerings. The first system covers the first four measures, with lyrics: "If you're happy and you know it, clap your hands." The second system covers the next four measures, with lyrics: "If you're happy and you know it, then your face will surely show it, if you're". The third system covers the final four measures, with lyrics: "happy and you know it, clap your hands." Each system is divided into a "Triads" section (first two measures) and a "4" section (last two measures). Chords shown include C7, F, and Bb. Fingerings are indicated by numbers 1-5. Yellow ovals highlight specific notes or chords. A red dot on the C7 chord in the first system indicates a barre on the first fret.

Eensy, Weensy Spider

North Carolina Children's Song

Lively *b: 3* Beats: 2 - adding the Eb and Bb7 chords

System 1:

- Staff 1 (Eb):** Chord Eb (F4, Ab4, Cb5). Notes: E4, F4, G4, Ab4, Bb4, Cb5. Fingering: 2.
- Staff 2 (Bb):** Chord Bb (G4, Bb4, D5). Notes: G4, Ab4, Bb4, Cb5, D5, E5. Fingering: 2.
- Staff 3 (Eb):** Chord Eb (F4, Ab4, Cb5). Notes: E4, F4, G4, Ab4, Bb4, Cb5. Fingering: 2.
- Staff 4 (Bb):** Chord Bb (G4, Bb4, D5). Notes: G4, Ab4, Bb4, Cb5, D5, E5. Fingering: 2.
- Staff 5 (Eb):** Chord Eb (F4, Ab4, Cb5). Notes: E4, F4, G4, Ab4, Bb4, Cb5. Fingering: 2.

System 2:

- Staff 1 ((Eb)):** Chord Eb (F4, Ab4, Cb5). Notes: E4, F4, G4, Ab4, Bb4, Cb5. Fingering: 2.
- Staff 2 (Bb):** Chord Bb (G4, Bb4, D5). Notes: G4, Ab4, Bb4, Cb5, D5, E5. Fingering: 2.
- Staff 3 (Eb):** Chord Eb (F4, Ab4, Cb5). Notes: E4, F4, G4, Ab4, Bb4, Cb5. Fingering: 2.
- Staff 4 (Bb7):** Chord Bb7 (G4, Bb4, D5, F5). Notes: G4, Ab4, Bb4, Cb5, D5, E5, F5. Fingering: 1, 2.
- Staff 5 (Eb):** Chord Eb (F4, Ab4, Cb5). Notes: E4, F4, G4, Ab4, Bb4, Cb5. Fingering: 2.

Lyrics:

Een- sy, ween- sy, spi- der went up the wa- ter spout. Down came the rain and washed the spi- der out. Out came the sun and dried up all the rain, And the eensy ween- sy spi- der went up the spout a- gain.

Alphabet Song

Traditional American School Song

Moderately #2 Beats: 4 - adding the A chord

--	--

Home on the Range - 1

Higley

Kelley

Moderately # 1 Beats: 3 - adding the Cm and Em chords

NC
G
C
G
A
D7

Triads 4

Oh,
give
me
a
home
where
the
buf-
fa-
lo
roam,
Where
the
deer
and
the
an-
te-
lope
play

1 3 4 3 1

Where

G
C
G
D7
G

Triads 4

sel-
dom
is
heard
a
dis-
cour-
ag-
ing
word,
And
the
skies
are
not
cloud-
y
all
day.

1 3 4 1 2 1

Home on the Range - 2

Triads 4 5

G Home,
D7 home
G on
G the
Em range
A Where
D7 the
Where deer
and
the
an-
te-
lope
play,
Where

Detailed description: This diagram shows the first system of guitar chords for 'Home on the Range'. It consists of seven lines representing strings. The first line (G) has a triad of white circles on frets 1, 2, and 3. The second line (D7) has a red circle on fret 1 and white circles on frets 2 and 3. The third line (G) has a triad of white circles on frets 1, 2, and 3. The fourth line (Em) has a red circle on fret 2 and white circles on frets 3 and 4. The fifth line (A) has white circles on frets 1 and 2, and a red circle on fret 3. The sixth line (D7) has a red circle on fret 1 and white circles on frets 2 and 3. The seventh line (D7) has a red circle on fret 1 and white circles on frets 2 and 3. A green vertical bar highlights frets 4 and 5. Yellow ovals indicate fingerings: fret 1 on the 4th string, fret 4 on the 4th string, fret 5 on the 4th string, and fret 1 on the 7th string.

Triads 4

G sel-
dom
is
heard,
a dis-
cour-
ag-
ing
word,
And
the
skies
are
not
cloud-
y
all
day.

Detailed description: This diagram shows the second system of guitar chords for 'Home on the Range'. It consists of seven lines representing strings. The first line (G) has a triad of white circles on frets 1, 2, and 3. The second line (D7) has a red circle on fret 1 and white circles on frets 2 and 3. The third line (C) has a red circle on fret 1 and white circles on frets 2 and 3. The fourth line (Cm) has a red circle on fret 1 and white circles on frets 2 and 3. The fifth line (G) has a triad of white circles on frets 1, 2, and 3. The sixth line (D7) has a red circle on fret 1 and white circles on frets 2 and 3. The seventh line (G) has a triad of white circles on frets 1, 2, and 3. A green vertical bar highlights frets 4 and 5. Blue ovals indicate fingerings: fret 1 on the 1st string, fret 3 on the 1st string, fret 4 on the 1st string, and fret 1 on the 2nd string. Yellow ovals indicate fingerings: fret 1 on the 4th string, fret 2 on the 4th string, and fret 1 on the 5th string.

For He's a Jolly Good Fellow

Lively # 2 Beats: 2

Traditional British Song

Triads | 4

NC
D

G

D

A7

D

D7

G

D

A

D

2

1
3

5

2

For he's
a jol-ly good fel-
low,
For he's
a jol-ly good fel-
low,
Which no-bo-dy can de-ny.
Which

M-C's | 4

(D)

G

D

G

D

no-bo-dy can de-ny,
Which no-bo-dy can de-ny.

Return to Beginning...

Second Time, End Here.

Bingo











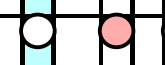
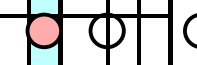
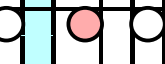

Brightly #: 1 Beats: 4 - adding the Am chord

Traditional Game Song

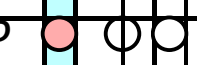
This diagram shows a guitar fretboard with 12 strings and 12 frets. The strings are labeled on the left as NC, G, C, D, G, D, G, Em, Am, D, G, C, Am, D, G. The fretboard is divided into two sections: 'Triads' (frets 1-3) and '4' (frets 4-12). The 'Triads' section has a light blue background, and the '4' section has a light green background. Colored circles represent notes: red for G, white for C, purple for D, green for G, orange for Em, yellow for Am, and pink for D. Numbers 1, 2, 3, and 4 are placed above the notes in the '4' section. To the right of the fretboard, the lyrics are written: 'There was a farmer had a dog and Bingo was his name-o. There was a farmer had a dog and Bingo was his name-o. There was a farmer had a dog and Bingo was his name-o. There was a farmer had a dog and Bingo was his name-o.' A yellow vertical bar is positioned between the Am and D strings in the '4' section.

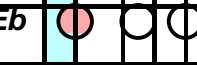
This diagram shows a guitar fretboard with 12 strings and 12 frets. The strings are labeled on the left as (G), C, D, G, D, G, Em, Am, D, G, C, Am, D, G. The fretboard is divided into two sections: 'Triads' (frets 1-3) and '4' (frets 4-12). The 'Triads' section has a light blue background, and the '4' section has a light green background. Colored circles represent notes: red for G, white for C, purple for D, green for G, orange for Em, yellow for Am, and pink for D. Numbers 1, 2, 3, and 4 are placed above the notes in the '4' section. To the right of the fretboard, the lyrics are written: 'was a farmer had a dog and Bingo was his name-o. was a farmer had a dog and Bingo was his name-o. was a farmer had a dog and Bingo was his name-o. was a farmer had a dog and Bingo was his name-o.' A yellow vertical bar is positioned between the Am and D strings in the '4' section.

Pages on Which All 15 Chords Are Introduced

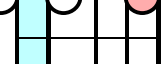
Page	Root Position	First Inversion	Second Inversion	Seventh Chord
4	C 	Triads 	Triads 	G7 
6			G 	D7 
8			F 	C7 
10				A7 
13	D 			
17		Bb 		
18	Eb 			Bb7 
19		A 		
21	Em 			
	Cm 			
23		Am 		

The Chord Positions - Chosen to keep the hand in the blue octave.